



355E

Telehandler

 **103 kW**

 **5.5 t**

 **8.5 m**

 **MULTI CAB**

Stage IV
Tier 4 final

355E Advanced. The new telehandler.

Our telehandlers are visibly different and already an eye catcher with the elevating cab. But they also convince through the design in detail, from the travel drive to the kinematics and the boom as well as clever options.

With a specialized team, the SENNEBOGEN team at the Wackersdorf works develops and produces this unique range of products, built for users who expect more than a classic telehandler. Let us convince you!



What distinguishes the SENNEBOGEN group:



Erich Sennebogen snr. influenced the construction equipment and crane technology worldwide for more than six decades.

At the age of 21, Erich Sennebogen snr. founded his own company SENNEBOGEN in 1952.



We think and we act long-term.

Our sound and continuous company development as a family enterprise leads to a high degree of reliability and performance in the entire group of companies.



Works III in Wackersdorf is one of our three individually established production locations in Germany.

Right here, the telehandler is produced in high production depth. From construction to steel work - Made in Germany.

355E The advantages at a glance

Unique overview

ROPS / TOPS tested
(FOPS optional)

Best transmission of
force through Z-Kinematics

Air conditioning
system as standard

MULTI CAB

Elevating cab

Sturdy steel structure
for demanding applications

Tier 4 final engine
with high power
and torque

Swing axle lock
(optional)

Reversible fan as standard

Powerful drive train for high tractive
forces and driving speeds

Leveling system for more stability in inclined positions (optional)

Huge steering angle – small turning radius

Multifunctional –
hydraulics for many attachments



355E Others talk about visibility – we provide it

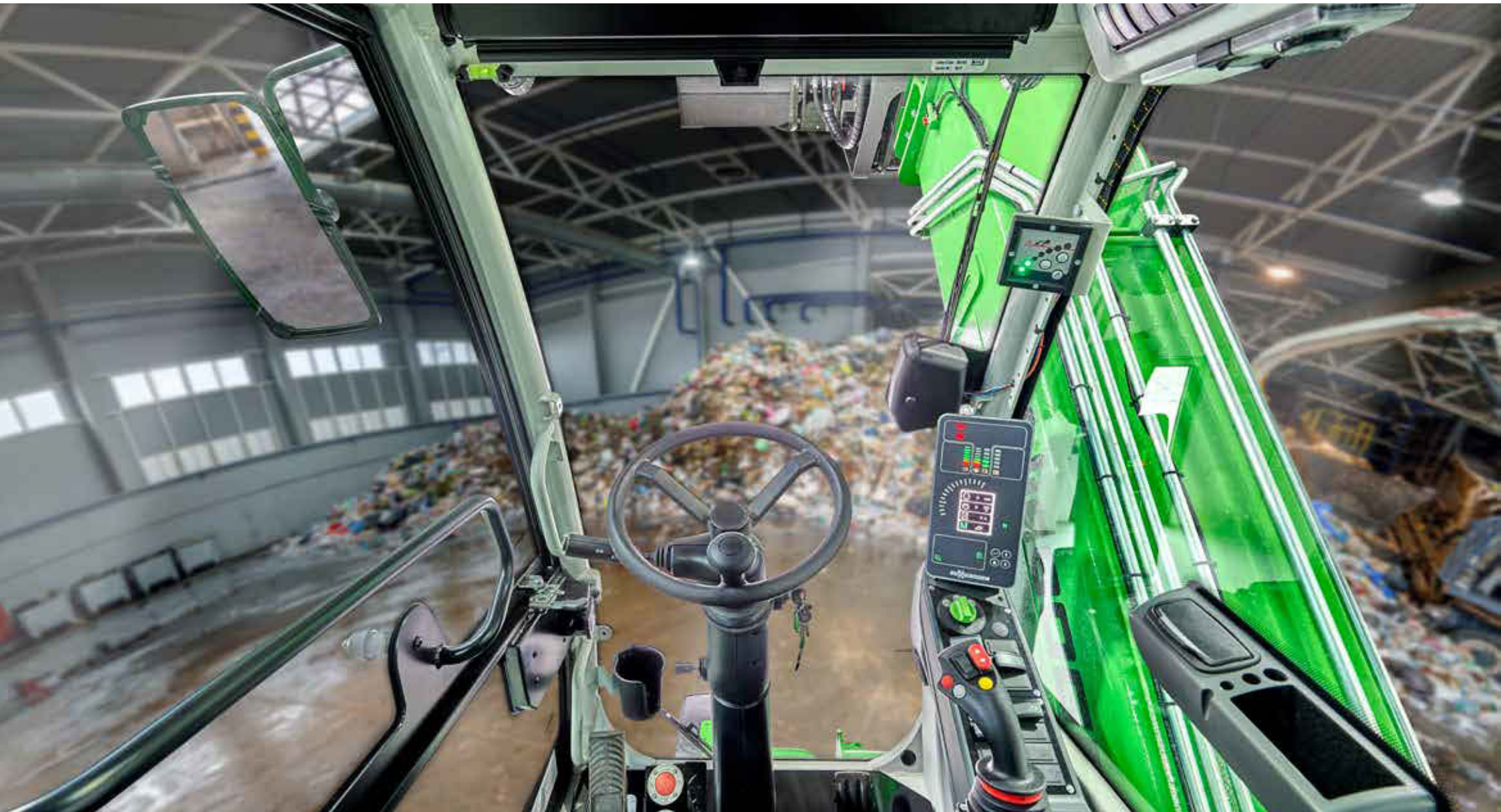

355E Optimal visibility

- **Optimal loading thanks to best overview**
into the truck or container through 4.25 m eye level with the elevating cab
- **Safety even when maneuvering**
Good view of all four tires of the machine
- **More overview and safety**
Real 360° all-round view through large glass windows

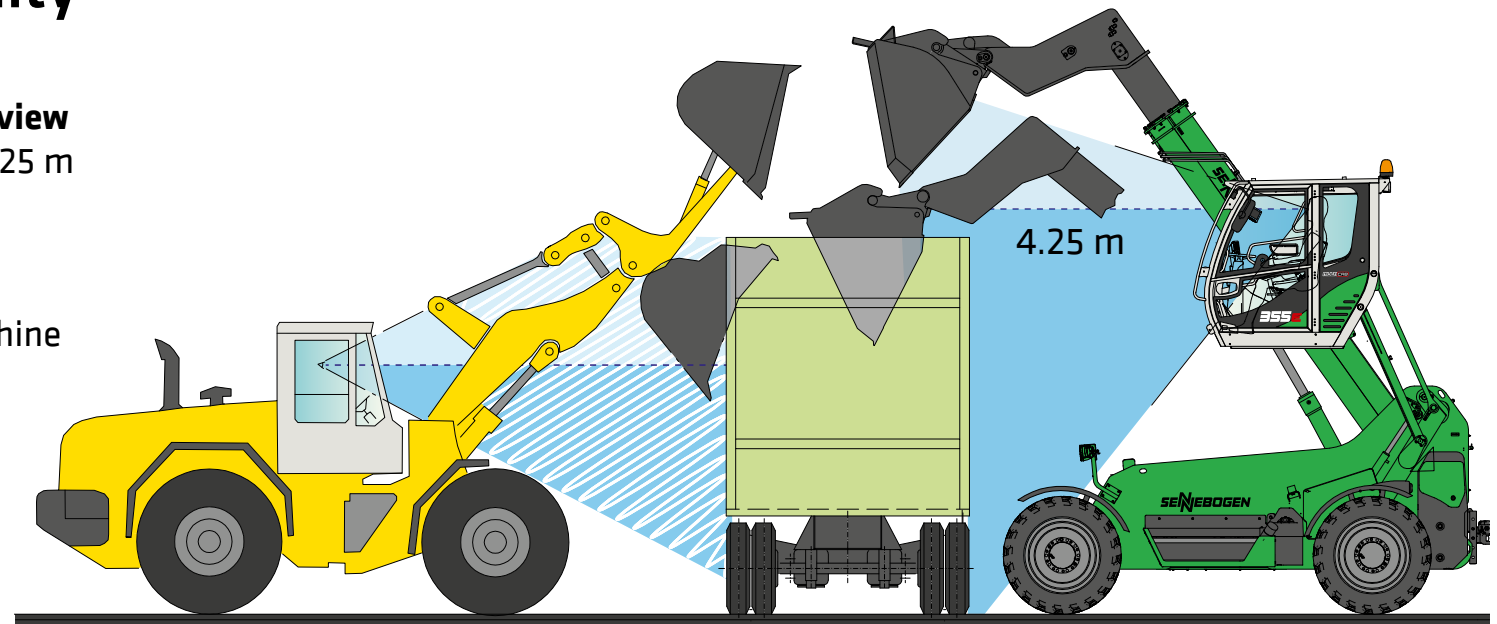

Perfect view – even to the right
over the telescopic arm





Robust in every detail

Frame steelwork

The machine's high-tensile massive steel frame meets the highest requirements for service life and has been optimized using the FEM (finite element method). It truly excels in demanding dynamic operating conditions.

Steel construction is done in-house and with lots of experience, allowing SENNEBOGEN to guarantee ultimate quality.

Telescopic arm steelwork

The robust telescopic arm has been designed with state-of-the-art tools and is engineered for heavy-duty operation. The massive wall thickness of all components ensures the particularly high rigidity.

The central mounting and the well thought-out design of the arm optimally transfers forces to the body. The end position damping on both ends of the telescopic cylinder allows stress-free work.

The structure is guided centrally and laterally for optimal absorption of thrust forces, thereby avoiding any deflection of the robust body. The telescopic arm is mounted in an optimal position, allowing the operator to see over the side of the arm from the elevating cab at any time.



355E Strong like no other

The telehandler with maximum break-away force

The SENNEBOGEN 355 E is a true powerhouse when it comes to shovel operation. Its Z-Kinematics system ensures that forces are induced into the shovel in an optimal manner, as is known from wheel loader technology.

Changing tools at the push of a button

The robust hydraulic SENNEBOGEN quick-change system is the perfect addition to the telehandler's Z-Kinematics: A reinforced frame - generously dimensioned bolts - double-acting locking cylinders - all controlled at the push of a button.

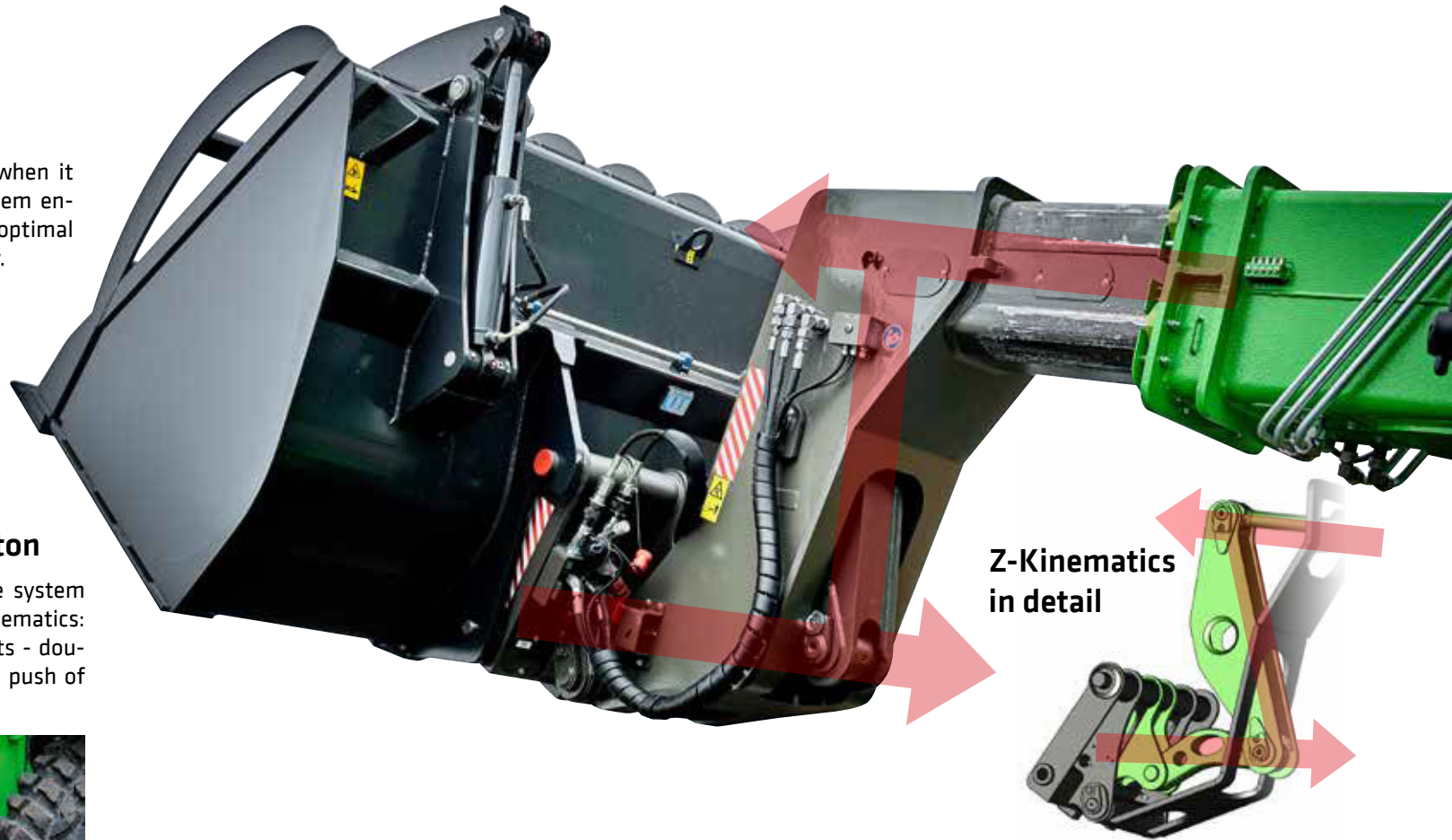





**According to your wishes:
Always an optimal mix of traction and speed**



355E Always full power

The powerful and clever drive train

The continuously variable travel drive of the 355 E is always supplied with plenty of power by a carefully matched unit of diesel engine and hydraulic pump.

The innovative control of the drive unit ensures that the drive motor in the Compact Drive gear provides power for fast traveling or a high torque when necessary.

You do not have to do anything: the system automatically provides the optimal setting for fast travel speed, managing an incline, or picking up heavy material.

In standard mode, you can travel at up to 20 km/h, but the unit has enough power to speed you up to nearly 40 km/h if needed.



Max. 85 kN tractive / thrust force



Max. 40 km/h travel speed



COMPACT DRIVE®

The Compact Drive gear, which is fitted as standard, works extremely effectively and fuel-efficiently in a closed circuit. The technically highly developed components of the gear - adjustable hydraulic motor and toothed gear - interact optimally and ensure an extremely flexible operating range.

This unit equally impresses with a compact and space-saving design that has been engineered for ultimate durability and extreme reliability - whether at high speeds or with high thrust/tractive forces.

355E Working in the comfort zone



Ergonomics in every detail



Comfortable pedals for continuous cab height adjustment

AC as standard



Air conditioning system as standard for a pleasant working environment



The console and controls are resonant



Storage spaces behind and beside the seat



Connections: USB, 12 V, 24 V



Extensive lighting options



Ideal working comfort

Boom damping and
vibration-damped cab



355E Sophisticated technology - permanently reliable



Well thought-out in every detail

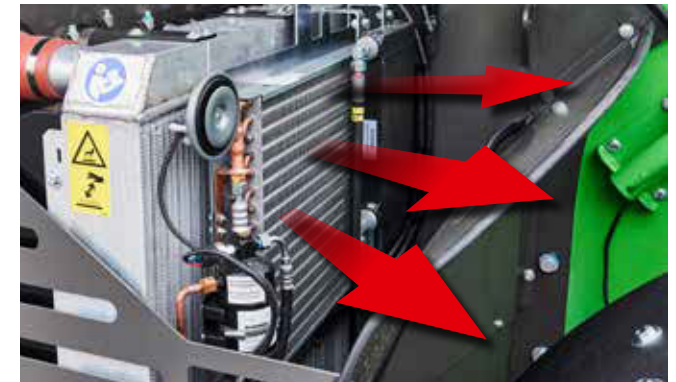

The SENNEBOGEN 355 E ensures your productivity. A powerful reversible fan comes as standard. It reliably prevents the air intake from clogging to ensure maximum cooling performance - even under the most adverse conditions.



More work, less refueling stops: Thanks to an enormous diesel tank, the 355 E let you keep working even during multiple-shift operation.



Controlled use of power on slopes



355E Technical data

OPERATING DATA

Operating weight ¹	11,800 kg
Stacking height	8,500 mm
Max. working load (LSP 600 mm)	5,500 kg
Max. working load at max. height	4,850 kg
Max. working load at max. reach	2,400 kg
Max. travel speed	20 (40) km/h
Tractive force ²	90 kN
Break-away force at the shovel ³	85 kN

ENGINE

Type	FPT
Emissions level	Tier 4 final
Exhaust aftertreatment	DOC + SCR
Engine power	103 kW
Displacement	4.5 l
Max. torque	630 Nm

WORKING HYDRAULICS

Operating pump	Load-sensing axial-piston variable displacement pump
Output	200 l/min
Working pressure	310 bar
Output ZH1 ⁴	65 l/min

1) according to ISO 6016 (weight of the machine with complete standard equipment, without load, completely filled fuel tank, with filled liquid tanks [water, hydraulic oils, brake fluid] and the weight of the operator [75 kg ± 3 kg])

2) depending on the machine version

3) calculated

4) ZH = additional hydraulics

TRANSMISSION OF FORCE

Steering angle	41°
Differential lock	100% at rear axle
Service brake	internal hydraulic brake
Parking brake	Hydraulic spring brake cylinders

CAPACITIES

Diesel tank	200 l
Hydraulic oil tank	120 l
SCR tank	20 l



355E Lifting and load capacities

Lift chart and working area

without frame levelling function / with oscillating axle interlock

Operation with lifting fork

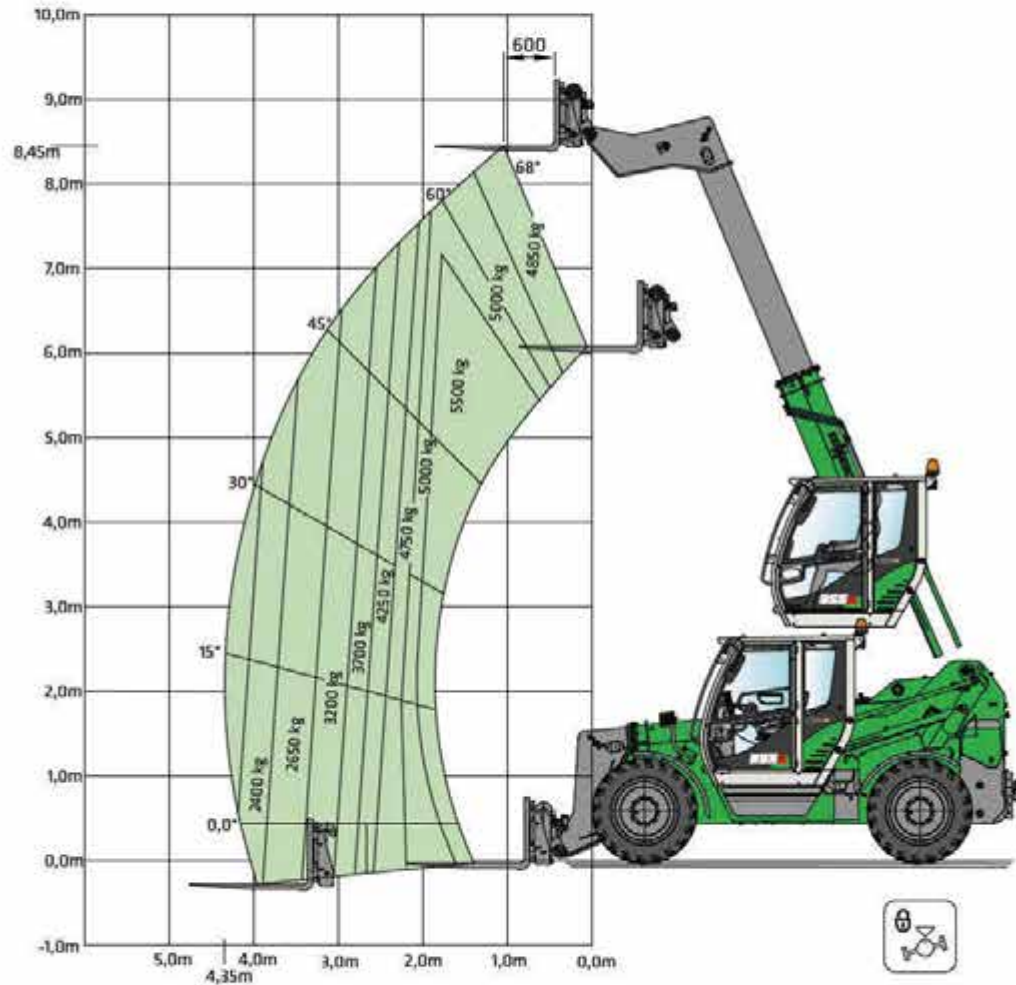

Values according to safety norm DIN EN 1459 / DIN ISO 22915-14 and EN 474-3 / ISO 8313. They apply to SENNEBOGEN standard lifting forks with a deviation of max. +/- 5° from the horizontal.

Load capacities and operating range

without frame levelling function / with oscillating axle interlock

Operation with shovel

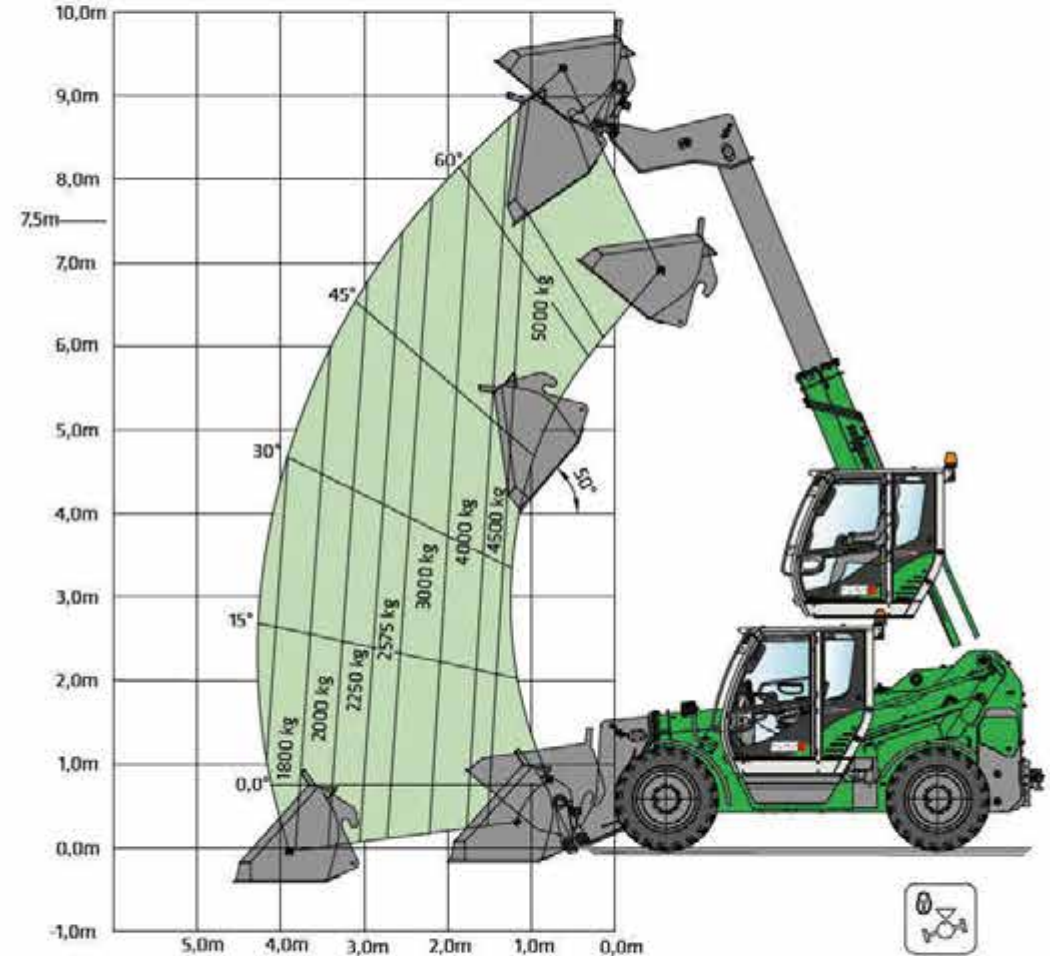

Load capacities according to EN 474-3 / Iso 8313. They do not exceed 50% of tipping load. Net weight of shovel is part of the load capacity.

355E Lifting capacities

Lift chart and working area

with frame levelling function / with oscillating axle interlock

Operation with lifting fork

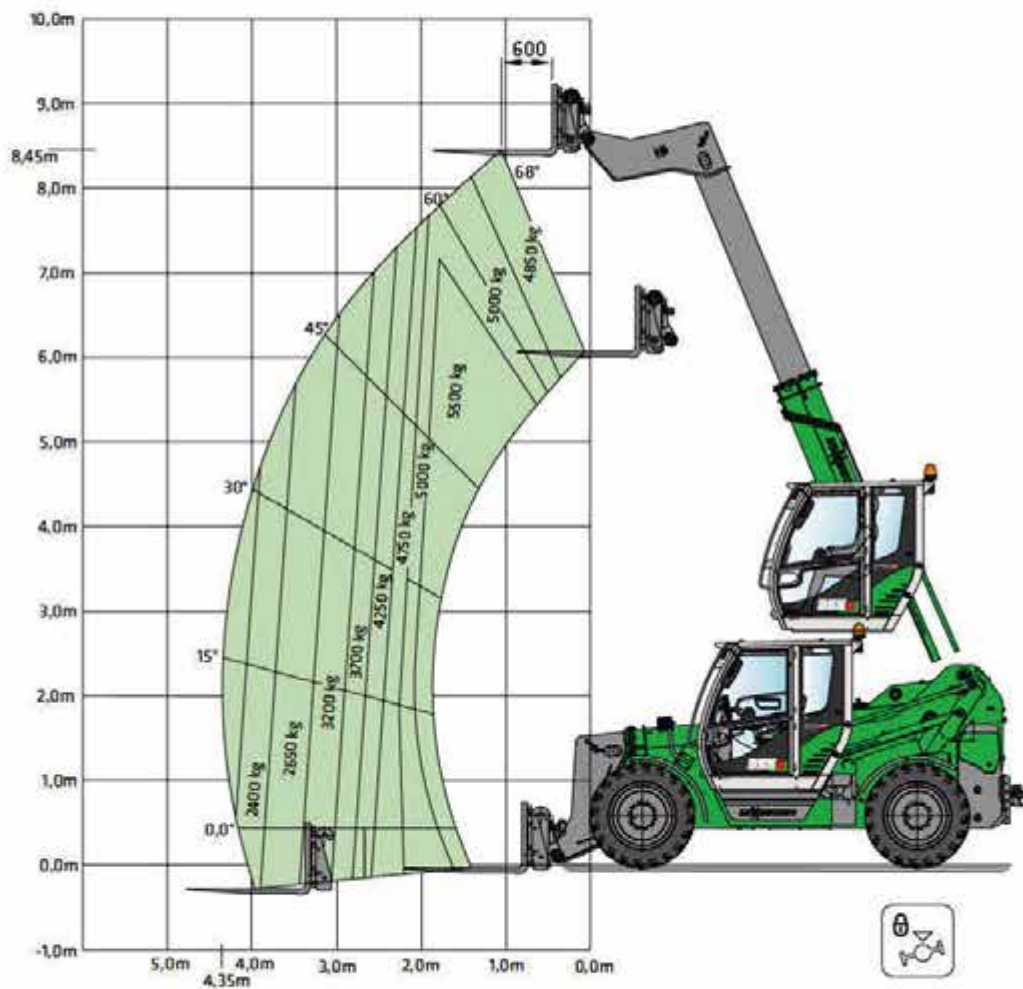

Values according to safety norm DIN EN 1459 / DIN ISO 22915-14 and EN 474-3 / ISO 8313.
They apply to SENNEBOGEN standard lifting forks with a deviation of max. +/- 5° from the horizontal.

Lift chart and working area

without frame levelling function / without oscillating axle interlock

Operation with lifting fork

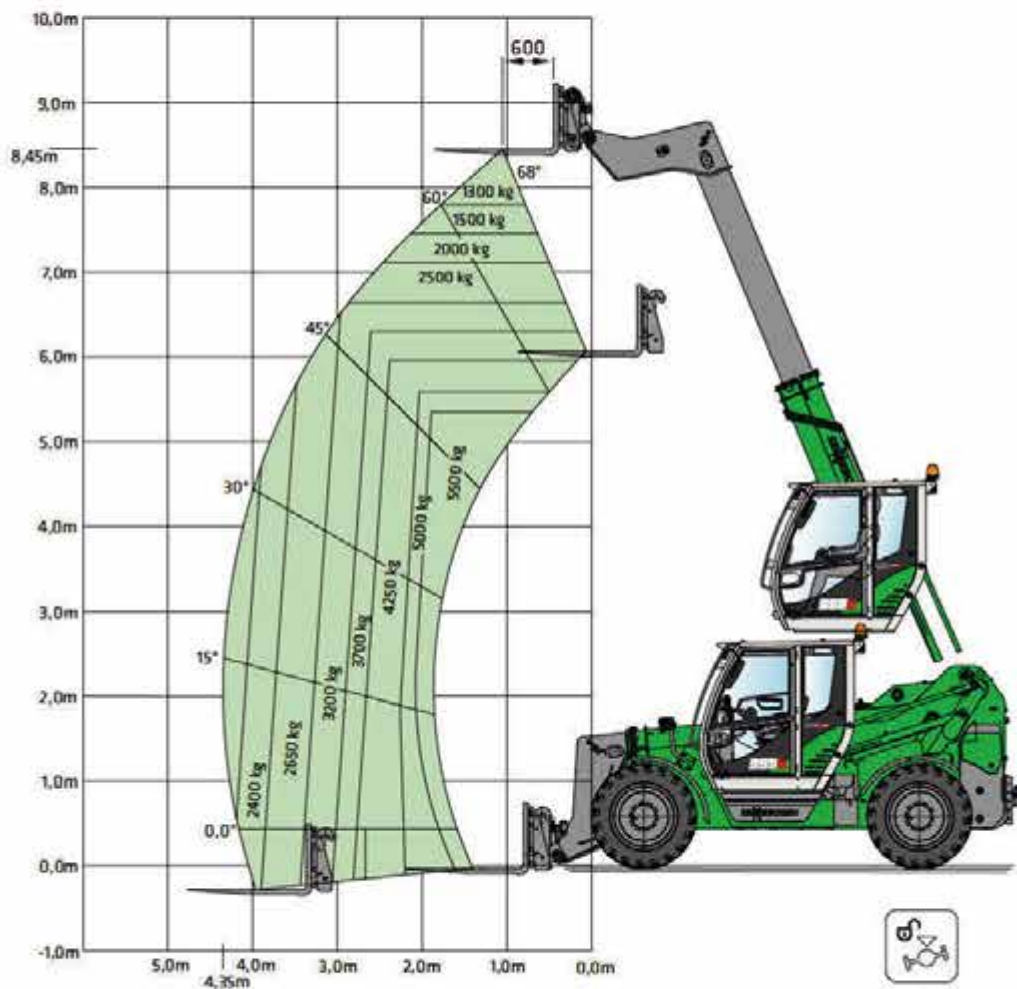

Values according to safety norm DIN EN 1459 / DIN ISO 22915-14 and EN 474-3 / ISO 8313.
They apply to SENNEBOGEN standard lifting forks with a deviation of max. +/- 5° from the horizontal.



Total power
Total overview

4.25 m eye level



355E Standard equipment and options

BASIC MODEL

355 - E-series SENNEBOGEN telehandler (Tier 4 final) 103 kW	●
355 - E-series SENNEBOGEN telehandler (Tier 3) 104 kW	○
Electric engine preheating 230 V	○
Pre-separator for air filter, approx. 98% coarse-particles separation	○
Reversible fan	●

TIRES

460/70-24 Camso MPT 753	●
500/70 R 24 Nokian TRI Steel	○
460/70 R 24 Alliance MPT	○
460/70 R 24 Alliance Multiuse	○
460/70 R 24 Michelin Bibload Hard Surface	○
500/70 R 24 Michelin Bibload Hard Surface	○
375/85-24 Camso MPT solid tires	○
15.5 R 25 Michelin X Mine D2	○

DRIVE AND STEERING

Continuously variable travel drive 20 km/h	●
Continuously variable travel drive 30 km/h	○
Continuously variable travel drive 40 km/h	○
Crawling-mode function and speed limiter	○
Level control of the front axle	○
Cover of the drive train, underbody center areas	○

OPTIONS FOR DRIVE AND STEERING

Shunting coupling 3 t	●
Automatic trailer coupling, height-adjustable	○
Air brake system for towing operation	○

CAB AND EQUIPMENT

SENNEBOGEN Multicab comfort cab, vibration-damped with nitrogen accumulators	●
Air conditioning system with central control panel	●
Seat belt / 2 inches	●
Spring-suspension driver seat, height-adjustable	●
Air-suspended comfort driver seat with seat heating	○
Windshield with armored glass	○
Polycarbonate safety glass for cab panels left and right incl. door	○
Safety glass for cab panels left and right; polycarbonate door glass for Multicab comfort cab	○

Roof window in armored-glass design	○
Windshield wiper for glass roof panel	○
Windshield wiper for lower cab windshield	○
Windshield wiper for rear window	○
Protective grating for roof window (level 1) light version	○
FOPS protective grating	○
Sunblind for roof window, internal	○
Sunblind for windshield, internal	○
Radio (USB, SD, MP3, Bluetooth)	○
Activated carbon filter for cab, 5 filter kits, enclosed	○

● standard ○ optional

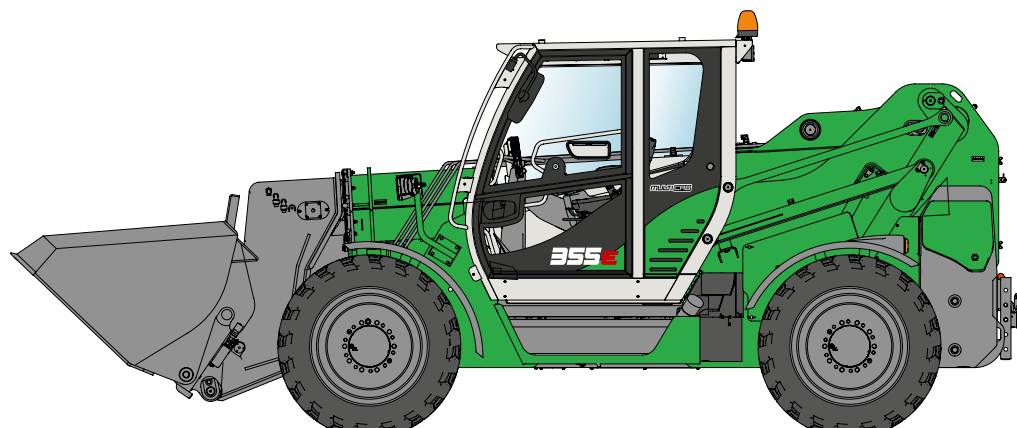



Optional level control

The problem solver for almost every oblique position



355E Standard equipment and options

OPTIONAL EQUIPMENT

Mirrors, right and back	●
Camera system - basic package with 1 camera	○

HYDRAULIC OIL FILLING

Hydraulic oil Shell Tellus S2 VA 46	●
Bio-oil filling (PANOLIN HLP Synth 46)	○
Hydraulic oil Shell Tellus S4 VX 32 (low-temperature oil)	○

EQUIPMENT

Boom damping	○
Dirt scraper for telescopic arm	○

ADDITIONAL FUNCTIONS for attachments

Continuous operation ZH1	○
ZH3- Supplemental hydraulic circuit on boom head*	○
ZH2- Supplemental hydraulic circuit at rear end*	○
Power socket for front attachments, 4-pole	○

LIGHTING AND TRAVEL-MODE ALERT

Standard lighting package incl. lighting in compliance with road traffic licensing regulations	●
2 LED headlights on basic boom: one on the left and one on the right side	○
All-round lighting package (incl. lighting in compliance with road traffic licensing regulations)	○
1 beacon on the cab	○

SPECIAL ITEMS

Electric heater for hydraulic tank, 230 V	○
---	---

QUICK-CHANGE MECHANISM

SENNEBOGEN hydraulic quick-change mechanism	●
VOLVO hydraulic quick-change mechanism	○

PAINTWORK / COATING

Standard paintwork RAL 6018 green / RAL 7038 light-gray / RAL 7022 gray	●
Special paintwork (single-color) in RAL color	○
Special paintwork (multi-color) in RAL color	○
Special paintwork only for Multicab in RAL color	○

SENtrack TELEMETRY SYSTEM

SENtrack telemetry system for E-series diesel machines including connection fees	○
Preparation for SENtrack telemetry retrofitting of E-series diesel	○

● standard ○ optional

* ZH = additional hydraulics

355E Equipped for many uses

Powerful working hydraulics

Powerful drive, low consumption: The 355 E ensures operation at the optimal operating point through a smart control system that performs load sensing between diesel engine and hydraulic pump. The result: Each work function always receives the hydraulic power it needs for optimal operation. No more, no less.

The control block responds very quickly to the electric actuation inputs from the joystick: Signals are transferred to the machine nearly instantaneously and converted into power.

In addition to the main functions of hoist cylinder, tilting cylinder, telescopic cylinder and the elevating cab, the working hydraulics controls the additional hydraulic connections just as effectively.

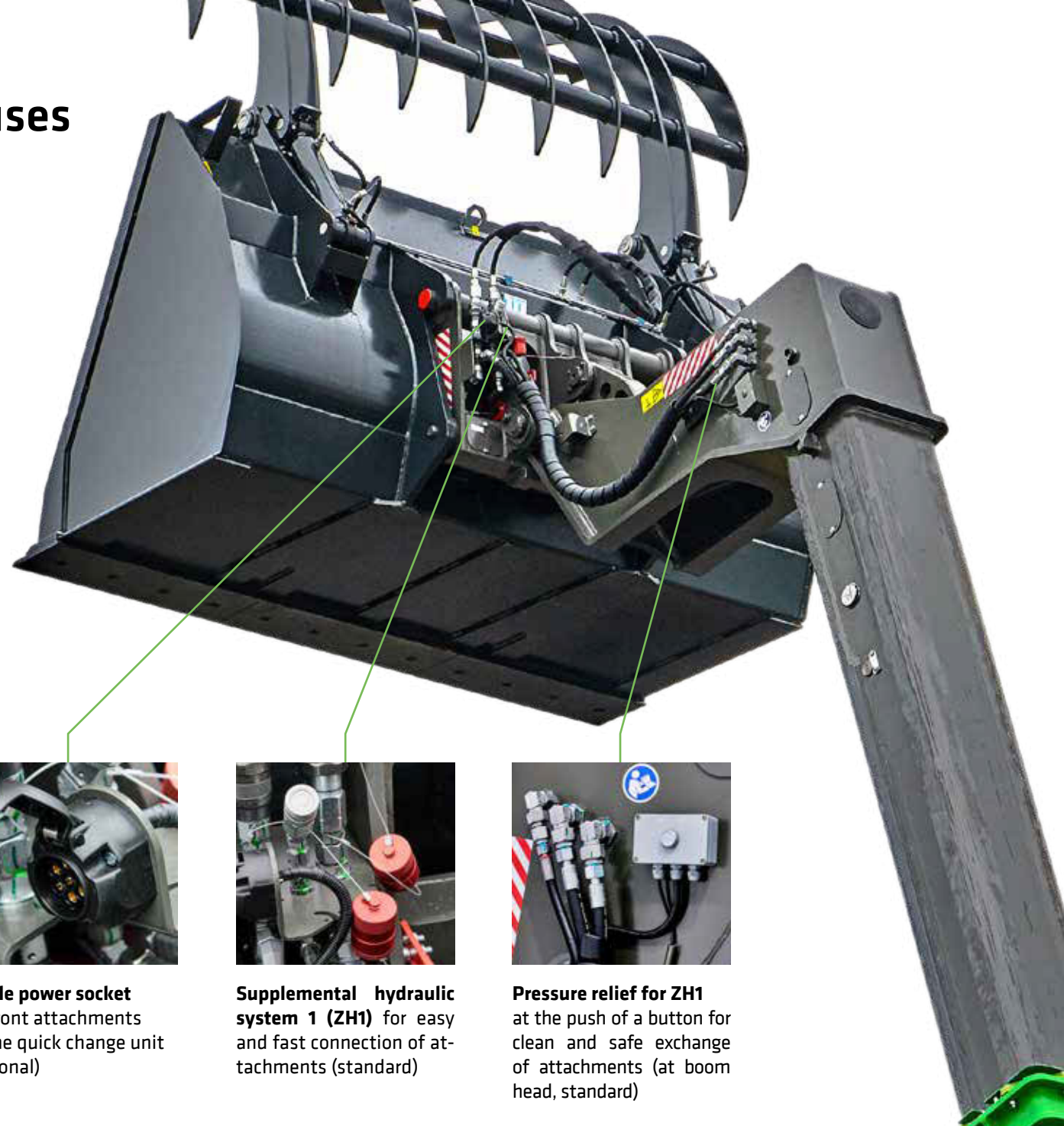

H-ZH rear-end supplemental hydraulic system hydraulic connection at rear end for trailers, etc. (optional) attachments (optional)



ZH2 additional hydraulic system for the operation of demanding attachments with multiple hydraulic functions (optional)

Continuous operation of ZH1 with selectable oil volume for custom attachments (optional)



4-pole power socket for front attachments on the quick change unit (optional)



Supplemental hydraulic system 1 (ZH1) for easy and fast connection of attachments (standard)



Pressure relief for ZH1 at the push of a button for clean and safe exchange of attachments (at boom head, standard)

355E Shovels and bulk material weight

SOIL SHOVEL 1

- 1.6 m³ with and without teeth
- Bulk material density: approx. 1.8 t/m³
- Shovel weight: approx. 610 kg



LOADING SHOVEL 2

- 2.5 m³ for bulk material density of approx. 1.2 t/m³ (shovel weight: approx. 870 kg)
- 3.0 m³ for bulk material density of approx. 1.1 t/m³ (shovel Weight: approx. 960 kg)



HOLD-DOWN SHOVEL 3

- 2.5 m³ incl. reversible blade bolted to underside, for bulk material density of approx. 1.4 t/m³ (shovel weight: approx. 1.480 kg)
- 3.0 m³ incl. reversible blade bolted to underside, for bulk material density of approx. 1.0 t/m³ (shovel weight: approx. 1.560 kg)



LIGHT-GOODS SHOVEL 4

- 3.5 m³ for bulk material density of approx. 1.0 t/m³ (shovel Weight: approx. 840 kg)
- 4.0 m³ for bulk material density of approx. 0.9 t/m³ (shovel Weight: approx. 920 kg)



Bulk weights and guide values for shovel fill levels

MATERIAL	CONDITION	t/m ³	%	RECOMM.
Gravel	moist	1.9	105	1
	dry	1.6	105	1
	broken. grit	1.5	100	1
Sand	dry	1.5	105	1
	wet	1.9	110	1
Gravel sand	dry	1.7	105	1
	wet	2.0	100	1
Sand / clay		1.6	110	1
Clay	natural	1.6	110	1
	hard	1.4	110	1
Clay / gravel	dry	1.4	110	1
	wet	1.6	100	1

MATERIAL	CONDITION	t/m ³	%	RECOMM.
Soil	dry	1.3	115	1
	excavated wet	1.6	100	2
Topsoil		1.1	110	1
Basalt		1.95	110	1
Granite		1.8	95	1
Sandstone		1.6	100	1
Slate		1.75	100	1
Bauxite		1.4	100	1
Limestone		1.6	100	1
Gypsum	broken	1.8	100	1
Coke		0.5	110	4
Slag	broken	1.8	100	1

MATERIAL	CONDITION	t/m ³	%	RECOMM.
Glass waste	broken	1.4	100	3
	whole	1.0	100	3
Compost	dry	0.8	105	3 4
	wet	1.0	100	3 4
Wood chips / sawdust		0.5	110	4
Paper	shredded / loose	0.6	110	3 4
	waste paper / cardboard	1.0	110	3 4
Coal	heavy	1.2	110	2
	light	0.9	110	2
Garbage	household waste	0.5	100	3 4
	bulk waste	1.0	100	3 4

355E Tires

Decisive: rubber and tread

No matter what type of operation, the ground surface is the contact interface to the machine, which only offers optimum safety with the right tires. Further to rubber compound and tread design, the tire size is also an important selection criterion.

We give you the best tires for your application. Trust in our experience and let us advise you. For best performance, safety, and service life.



Selection of tires

STANDARD

CAMSO MPT 753
460/70-24

Universal tire with good traction and balanced driving behavior



INDUSTRY

NOKIAN TRI STEEL
500/70 R24

MPT tread steel-reinforced for industrial and recycling plants



OFF-ROAD

ALLIANCE MPT 580
460/70 R24

AS/MPT tread for moist and dirty ground in agriculture and forestry



CONSTRUCTION SITE

MICHELIN BIBLOAD
500/70 R 24

Radial; for construction sites and aggressive surfaces; comfort tires, smooth-running



RECYCLING

CAMSO MPT 793S
375/85-24

Solid tires 12.00-24.
Width approx. 300 mm





Small turning radius –
big effect

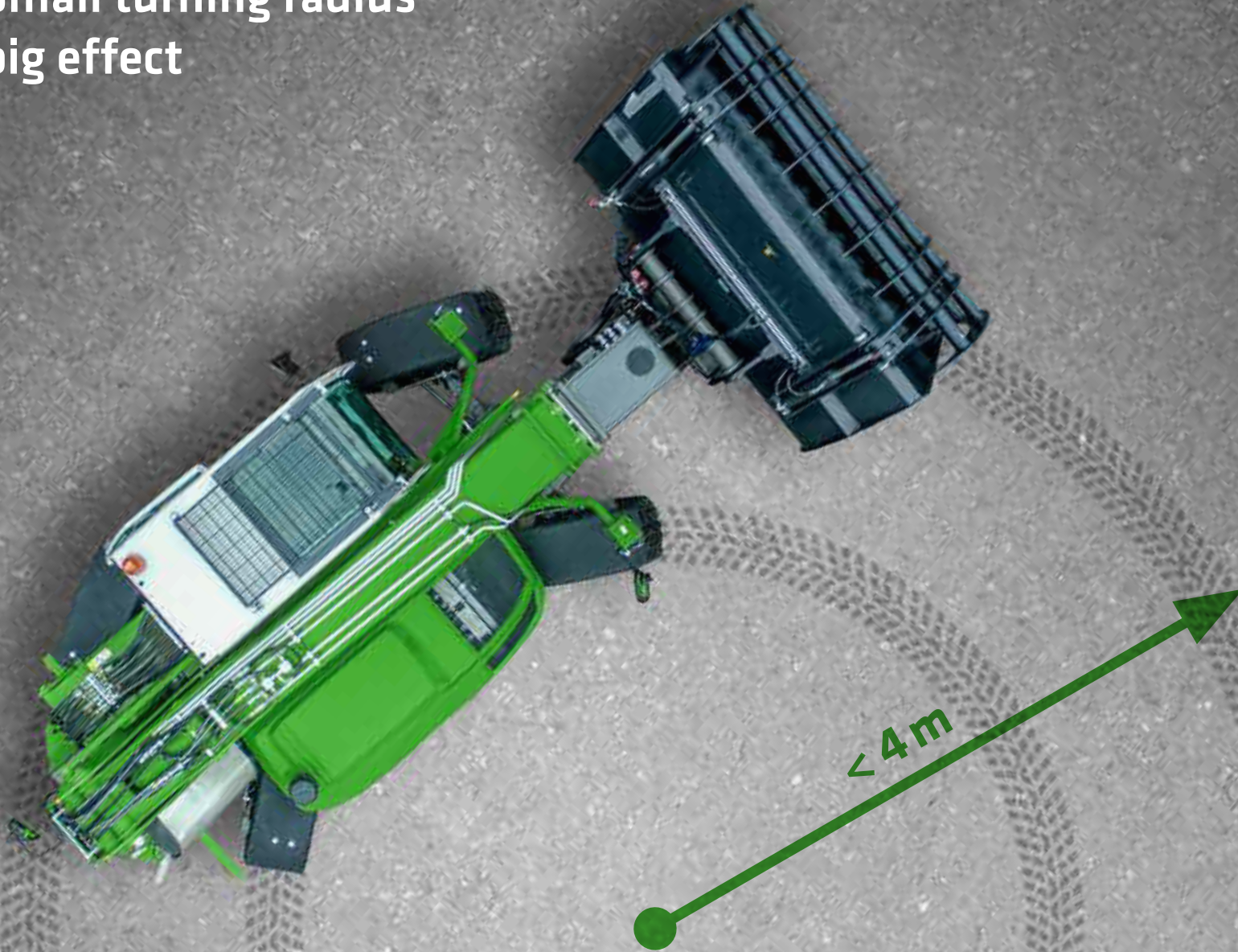

355E Dimensions and turning radius

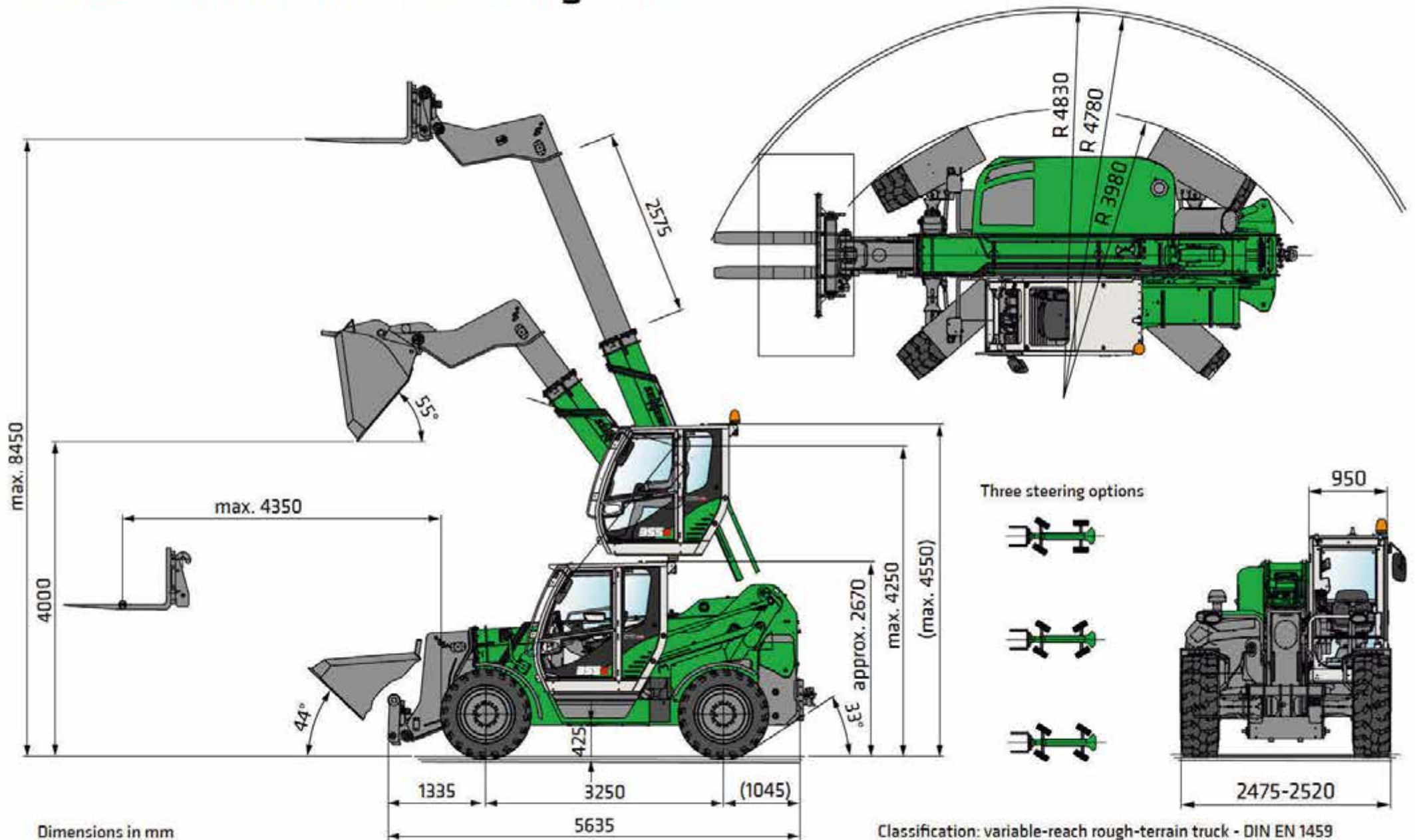

355E Your machine - multifunctional

A machine for all seasons

The SENNEBOGEN 355 E is a machine of many talents. In addition to the shovels and mechanical or hydraulic pallet forks, many other attachments can be used. The supplemental hydraulic systems and the electrical connection allow a multitude of useful tools to be operated safely and with sufficient power.

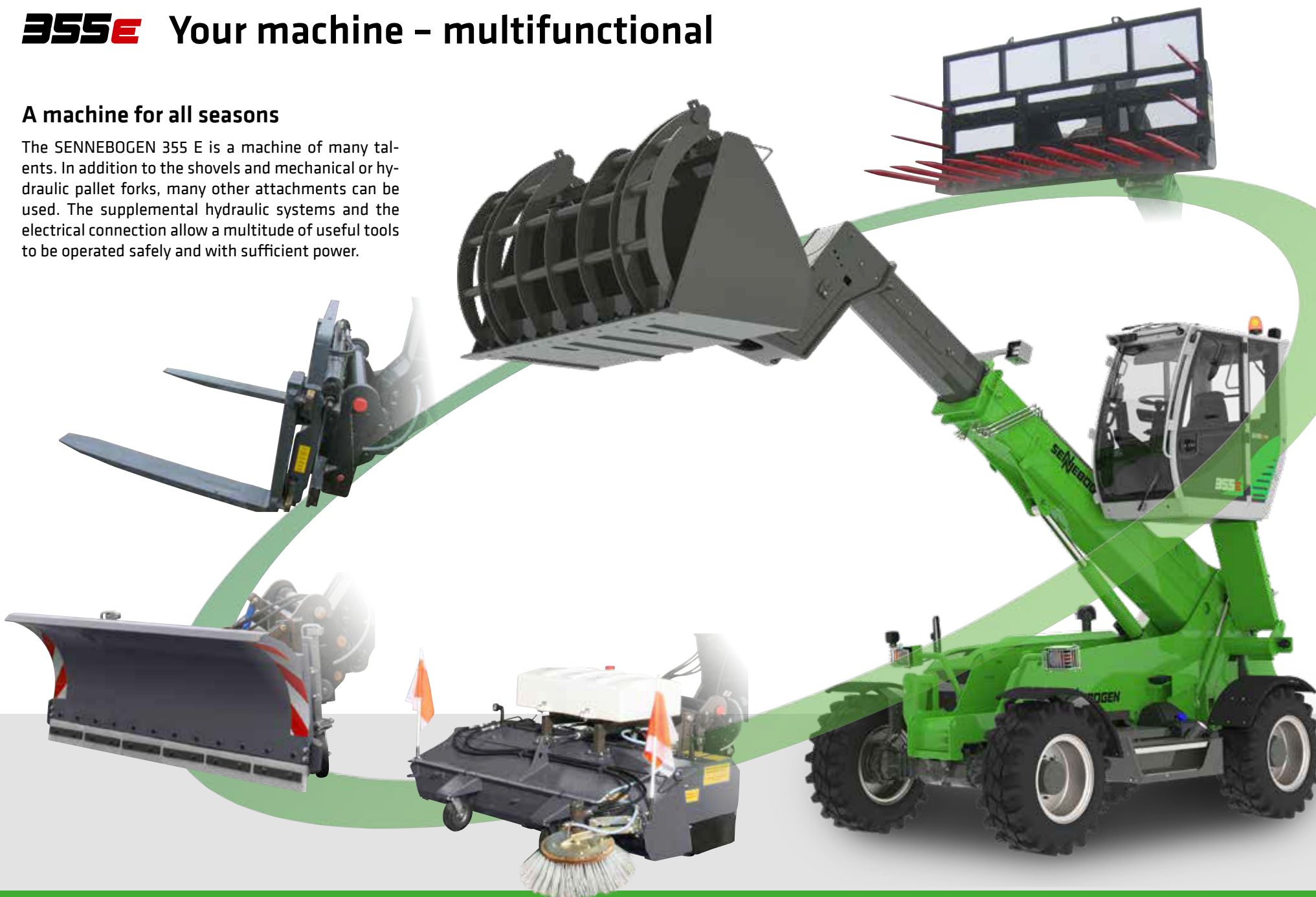

355E All-round service for you and your machine

Maintenance, service, spare parts and training

SENNEBOGEN guarantees the steel components of the 355 E (especially frame and telescopic boom) for three years or 10,000 operating hours, whichever occurs first.

The basis for this is an inspection for structural steel damage carried out at least once a year by an expert from SENNEBOGEN's sales and service partner.

Please ask your sales partner about this offer!



With just one hand:
spacious access to the engine compartment.



Clearly arranged control panel and display element incl. error code display.



We keep tens of thousands of spare parts in our central warehouse - ready for your call. This way you can rest assured that your machine remains available as long as possible.



Our service center offers you comprehensive technical support on all aspects of the operation, maintenance, and repair of your machine - on the telephone and directly on site.



At the SENNEBOGEN Academy, we offer a wide range of training courses for service technicians, operators, customers and employees.

355E Service-friendly



Easy access to all service points thanks to transversely mounted motor.



Telescopic boom slideways are accessible from the outside - easy maintenance and troubleshooting.



Very good accessibility to the radiator due to foldable condenser of the air conditioner / fuel cooler.

355E



Important valves and electrics are protected and accessible from the outside, even when the telescopic boom is lowered.



Best possible access to main control block, hydraulic oil tank and return-flow filter.



Ideal accessibility to the main fuse box with integrated overview plan.



355E

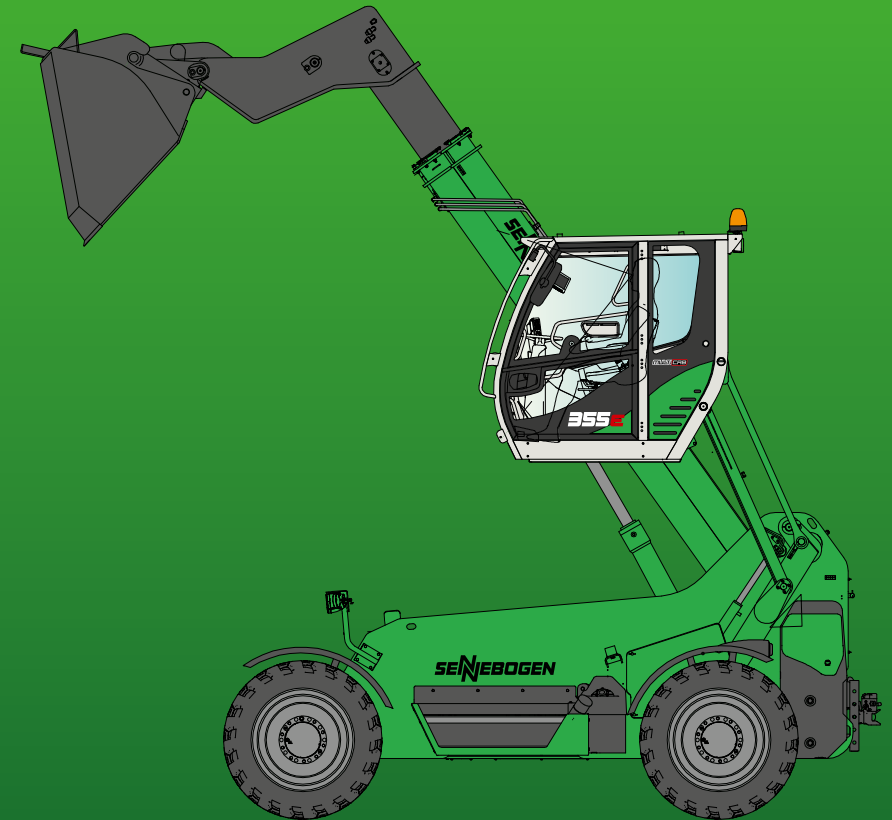

This catalog describes machine models, scopes of equipment of individual models, and configuration options (standard equipment and optional equipment) of the machines supplied by SENNEBOGEN Maschinenfabrik GmbH. Machine illustrations can contain optional equipment and supplemental equipment. Actual equipment may vary in a tolerance range depending on the country to which the machines are delivered, especially in regard to standard and optional equipment. All product designations used may be trademarks of SENNEBOGEN Maschinenfabrik GmbH or other supplying companies, and any use by third parties for their own purposes may violate the rights of the owners. Ask your local SENNEBOGEN sales partner about the equipment versions offered. Requested performance characteristics are only binding if they are expressly stipulated upon conclusion of the contract. Delivery options and technical features are subject to change. Errors and omissions excepted. Equipment is subject to change, and rights of advancement are reserved. © SENNEBOGEN Maschinenfabrik GmbH, Straubing, Germany. Reproduction in whole or in part only with written consent of SENNEBOGEN Maschinenfabrik GmbH, Straubing, Germany.

SENNEBOGEN
Maschinenfabrik GmbH
Sennebogenstraße 10
94315 Straubing, Germany

Tel. +49 9421 540-547
marketing@sennebogen.de

Order No. 295214
355-E-031920

SENNEBOGEN

 www.sennebogen.com