



## Pedestrian Pallet Truck Capacity 3000 kg T 30

SERIES 131

### Safety

Design of the Linde T 30 Electric Pedestrian Pallet Truck immediately catches the eye, but more than that it offers perfect operator protection. The low chassis skirt ensures that the wheels remain safely within the truck contours. Together with the rounded, smooth shape of the chassis and tiller head, this reduces all risk of pinching or snagging.

### Performance

Efficiency on the job is the Linde T 30's strong point. It gets all the power it needs from an AC motor. Forceful acceleration, 3000 kg load capacity and efficient brakes add up to productivity in service at any duty level.

### Comfort

Everything the Linde T 30 is meant to do it does easily. And does most of it faster. All controls can be operated with either hand without ever having to let go of the tiller. The handles are made of corrosion-resisting material that is pleasant to the touch.

### Reliability

The Linde T 30's rugged construction makes it a truck to rely on. Each fork supports a load of 2000 kg without bending. Smooth entry of the forks into closed pallets is ensured by the ramped tip, lead-in and narrow width (165 mm). Features that contribute to considerably longer truck lifetime as well as fast, easy and safe load handling.

### Service

Speed and economy continue over into truck diagnosis and preventive maintenance. CAN bus connectivity enables all truck data to be read out on a laptop computer by the service technician. Swift access to all components and maintenance-free AC technology play an additional part in keeping the Linde T 30's uptime up.

Linde Material Handling

*Linde*

# Technical data (According to VDI 2198)

Characteristics	1.1	Manufacturer		LINDE
	1.2	Model Designation		<b>T 30</b>
	1.3	Power unit		Battery
	1.4	Operation		Pedestrian
	1.5	Load capacity	Q (kg)	3000
	1.6	Load centre	c (mm)	600
	1.8	Axle centre to fork face (fork raised/lowered)	x (mm)	895/962
	1.9	Wheelbase (fork raised/lowered)	y (mm)	1359/1425
	Weights	2.1	Service weight (with battery item 6.5)	kg
2.2		Axle load with load, drive side/load side	kg	1255/2490
2.3		Axle load without load, drive side/load side	kg	580/165
Wheels/Tyres	3.1	Tyre treads: Polyurethane, Rubber		C + P / P
	3.2	Tyre size, drive side	mm	Ø254 x 102
	3.3	Tyre size, load side	mm	Ø85 x 105
	3.4	Auxiliary wheels (dimensions)	mm	Stab. Ø100 x 40
	3.5	Wheels number, drive side/load side (x=driven)		1x+2/2
	3.6	Track width, drive side	mm	544
	3.7	Track width, load side	mm	355/395/515
Dimensions	4.4	Lift	h <sub>3</sub> (mm)	125
	4.9	Height of the tiller arm in operating position, min./max.	h <sub>14</sub> (mm)	1140/1350
	4.15	Fork height, lowered	h <sub>13</sub> (mm)	85
	4.19	Overall length	l <sub>1</sub> (mm)	1810
	4.20	Length to fork face	l <sub>2</sub> (mm)	660
	4.21	Overall width	b <sub>1</sub> (mm)	790
	4.22	Forks dimensions	s/e/l (mm)	60 x 165 x 1150
	4.25	Fork spread	b <sub>5</sub> (mm)	520/560/680
	4.32	Ground clearance, centre of wheelbase min./max.	m <sub>2</sub> (mm)	25/150
	4.33	Aisle width with pallet 1000 x 1200 across forks	Ast (mm)	1950
	4.34	Aisle width with pallet 800 x 1200 along forks	Ast (mm)	2150
	4.35	Turning radius (fork raised)	Wa (mm)	1645
	Performance	5.1	Travel speed, with/without load	km/h
5.2		Lifting speed, with/without load	m/s	0.024/0.035
5.3		Lowering speed, with/without load	m/s	0.067/0.066
5.8		Maximum climbing ability, with/without load	%	10/20
5.10		Service brake		Electromagnetic
Drive	6.1	Drive motor, 60 minutes rating	kW	1.5
	6.2	Lift motor rating 15%	kW	1.5
	6.3	Battery according to DIN 43 531/35/36 A, B, C, no		DIN 43535 B
	6.4	Battery voltage/rated capacity (5h)	V/Ah	24/240
	6.5	Battery weight	kg	200
Others	8.1	Type of drive control		LAC-Controller
	8.4	Sound level at operator's ear	dB (A)	<70

Standard truck figures varying according to equipments.



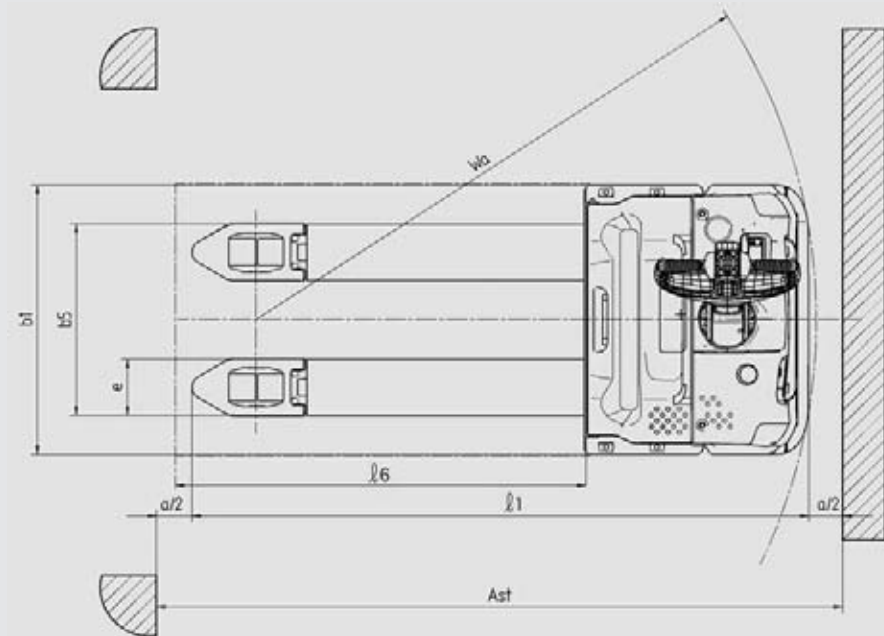
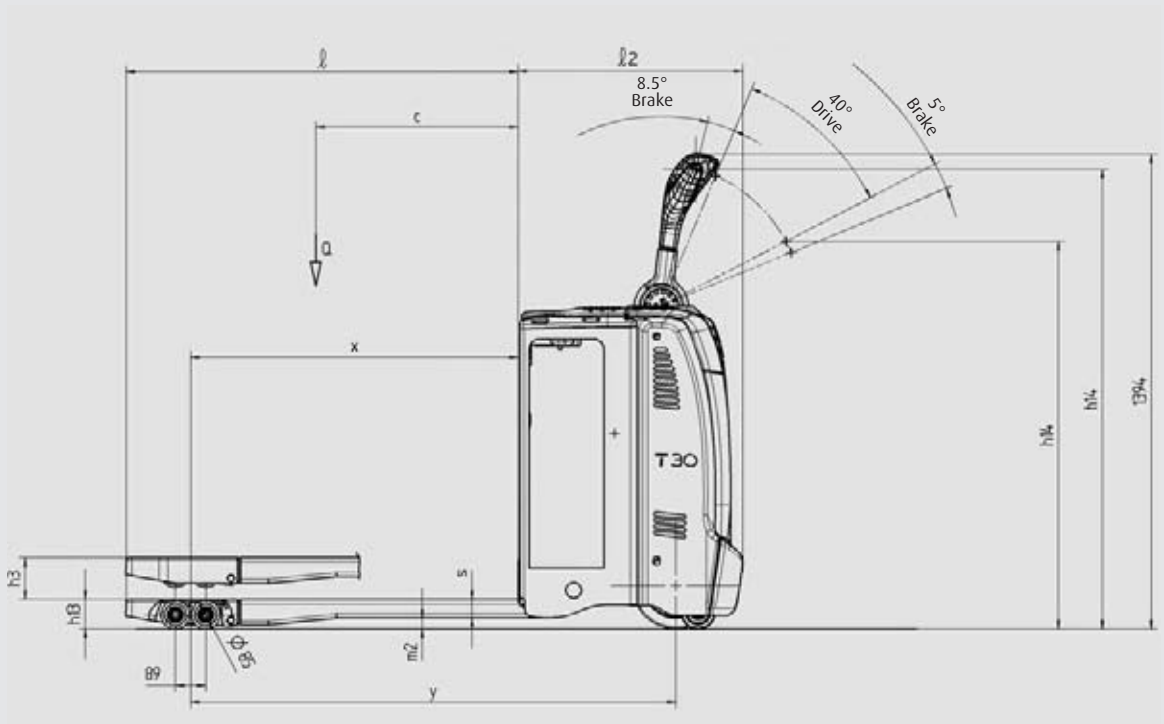

$$A_{st} = W_0 - x + \ell_6 + a$$

$a = 200 \text{ mm}$  security distance

# Equipment

## Standard equipment

Multifunction back lighted display

Key switch or Log in Pin code: ignition

Dedicated work station (with storage compartments)

Power assisted steering with a proportional steering resistance

Positive steering (drive wheel) feedback

Automatic speed reduction when cornering

AC motor

Automatic braking

Electromagnetic emergency brake acting proportionally to the load weight

Adjustable suspended castor wheels

Cushion drive wheel

Polyurethane castor wheels

Tandem polyurethane load wheels

Protection -10°C

## Optional equipment

Alternative fork dimensions

Drive wheels: polyurethane, cushion non-marking or wet grip

Polyurethane tandem load wheels Greasable

Clip board

Load backrest

Support for computer terminals or barcode reader

Battery trolley side battery change

Static battery roller stand for 2 batteries

Mobile battery roller stand for one battery

Cold store protection -35°C

Other options available on request.

# Features



## Brakes

- Automatic braking on releasing the travel switch
- Well controllable countercurrent braking
- Electromagnetic braking initiated by the emergency stop button acts on the drive motor, proportional to the load carried

## Chassis/Forks

- Rounded contours clear of sharp edges
- Robust pressed steel construction
- Low chassis skirt for operator safety
- Each fork tip can support a load of 2000 kg without bending

## Power steering convenience and safety

- Effortless proportional power-assisted steering
- Positive steering feedback enhances stability and comfort while travelling
- Automatic speed reduction on turns as a function of steering angle

## CAN bus system

- Electronic management of all components permitting quick and easy diagnosis
- All truck parameters can be configured by the service technician to achieve best performance in every application



## Workstation

- Digital multifunction display including component failure alarm, maintenance due alert, battery discharge indicator and hour meter
- Truck activated by PIN code or by ignition key
- Wide and deep storage compartments for wrapping paper, gloves, writing utensils, etc.

## AC motor

- Powerful, smooth-running motor, 1.5 kW at 100% performance
- Gradeability 13% fully loaded
- No rollback on uphill starting
- Top speed 6 km/h, loaded or unloaded
- Moisture- and dust-proof motor needs no maintenance

## Batteries and chargers

- Vertical battery change as standard, optionally side battery change left or right
- Wide range of batteries from 250 Ah (2PzS) to 500 Ah (4PzS)
- Wide range of standard and wall-mount chargers
- Battery locking system for side change secures battery in compartment and eases the battery change

Linde AG

Linde Material Handling Division, Postfach 10 01 36, 63701 Aschaffenburg, Germany  
Phone +49.60 21.99-0, Fax +49.60 21.99-15 70, [www.linde-forklifts.com](http://www.linde-forklifts.com), [info@linde-forklifts.com](mailto:info@linde-forklifts.com)

Linde Material Handling

*Linde*